

D057AHDXXSV.01 RANGE

2MP & 1.3MP Vandal Resistant Mini-Dome



Key Features

- 2MP resolution Starvis CMOS Sensor
- True Day/Night
- 10 x 850nm LEDs up to 10m illumination
- 2.5mm, 2.9mm & 3.6mm lens options
- Weatherproof & Impact Resistant IP67/ IK10
- Reverse image cut-loop
- E-11 R118 certified
- Plug and Play Connections
- Metal & ABS options

Ordering Information

D057AHD25SV.01-1080P: 1080P, T/DN, 2.5mm, Silver, 4-Pin, Starvis, IR 940Nm, RT, ABS
D057AHD29SV.01-1080P: 1080P, T/DN, 2.9mm, Silver, 4-Pin, Starvis, IR 940Nm, RT, ABS
D057AHD36SV.01-1080P: 1080P, T/DN, 3.6mm, Silver, 4-Pin, Starvis, IR 940Nm, RT, ABS
D057AHD25SV.01-960P: 960P, T/DN, 2.5mm, Silver, 4-Pin, Starvis, IR 940Nm, RT, ABS
D057AHD29SV.01-960P: 960P, T/DN, 2.9mm, Silver, 4-Pin, Starvis, IR 940Nm, RT, ABS
D057AHD36SV.01-960P: 960P, T/DN, 3.6mm, Silver, 4-Pin, Starvis, IR 940Nm, RT, ABS

N.B.

D056/57MAS Silver Surface mount wedge (D056/57MAB Black option)
.01 – BNC & Power Jack / .02 Stripped cable ends

Dimensions

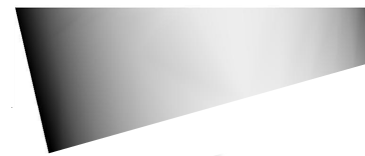
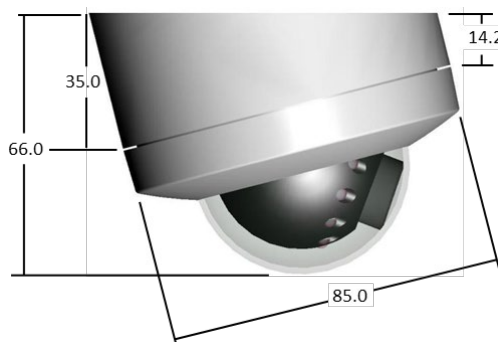
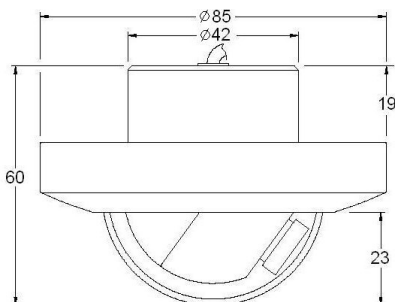

Angled mounting adaptor - **D056/57 SMAS / SMAB**

Avoids need for large aperture in mounting surface and adds 14.5° extra tilt.

Specifications

D057AHD25SV.01 Range

VIDEO	
Imaging Device	1/2.9" Colour CMOS Starvis Sensor
Total Pixels	1280 (H) x 1080 (V) & 1280 (H) x 960 (V)
Resolution	2MP & 1.3MP
Min. Illumination	Colour: 0.01 Lux @ F1.2 Monochrome : 0 Lux
Video Output	1 V pk-pk 75Ω
S/N Ratio	>50db (AGC off)
InfraRed Illumination	10 x 850nm
Illumination Distance	Up to 10m
LENS	
Focal Length	2.5mm, 2.9mm, 3.6mm
Field of View (H x V)	2.5mm: 100 ° ~ 78.9° / 2.9mm: 80.4 ° ~ 65.3° / 3.6mm: 67 ° ~ 53°
Lens / Mount Type	Fixed Iris / Board-in type
ENVIRONMENTAL	
Operating Temp/ Hum	-10°C ~ +50°C / 10-85% RH
Ingress Protection / Vandal Resistance	IP67 / IK10
ELECTRICAL	
Power	12V DC, ±35mA
Power Connector Type	4-Pin Aviation Plug
MECHANICAL	
Pan & Tilt Adjustment	Eyeball camera style
Colour / Material	Silver & Black (B) options, Metal or ABS options
Dimensions (W x H)	Ø85 x 60 mm
Weight	207g
CERTIFICATION	
	CE/UKCA IP67/VCA E9/E11/R118

Customers who bought our Analogue Micro-Dome Cameras also viewed:



Stortech IP Micro-Dome Series:

- SNV-20XX0C/FS
- SNV-20XX0C/FAS
- SNV-20XX0T/FS



Stortech 7" On-board Monitors:

- SMF-0730/A
- SMF-0730/HT
- SMF-0730/WH



Stortech Miniature Cameras:

- MPC-AHD
- MCC-1
- DCC1-AHD-RT

Stortech Electronics Ltd

Unit 2, Spire Green Centre, Pinnacles,
Harlow, Essex
CM19 5TQ

+44 (0) 1279 451100

www.stortech.co.uk

sales@stortech.co.uk



Stortech Electronics Ltd



Stortech Electronics Ltd